

# H037M

## 楔形3爪ビッグホローチャック

### WEDGE-HOOK type 3-JAW LARGE THROUGH-HOLE POWER CHUCK

#### 特長 Technical features

1. 大把握力で高速回転に対応し、大きな貫通穴をもっています。
  2. ワークの一部を貫通穴に挿入しての把握や、着座確認や主軸内クーラント仕様などの改造を行うのに適しています。
  3. パーワークを主軸後側から供給しての把握ができます。
1. Supports large clamping forces and high speeds and has a large through-hole.  
2. Suitable for clamping part of a workpiece inserted into the through-hole, checking the seating, or modifying spindle coolant specifications etc.  
3. Can feed and clamp a bar workpiece from the rear of the spindle.

仕様 Specifications	形式番号 Series number	H037M							
		4	5	6	8	10	12	(15)	
セレーションピッチ Serration pitch	mm	1.5	1.5	1.5	1.5	1.5	1.5	---	
爪のストローク (直径にて) Jaw movement (Dia)	mm	5.4	5.4	6.3	7.6	9.3	10.6	11.9	
プランジャストローク (シリンダストローク) (Cylinder stroke)	mm	10	10	15	18	22	25	28	
最大・最小把握径(外径) Recommended outside chucking diameter for standard soft blank jaws	最大 Max.	mm	110	135	165	210	254	304	381
	最小 Min.	mm	5	10	18	12	16	38	60
最高使用回転数 Max. Speed	r/min	7000	6000	5800	4800	4200	3200	2500	
許容シリンダカ Max. input force	kN	11.8	13.7	19.6	29.4	39.2	49.0	68.6	
把握力 Clamping force at Max. input force (Total jaw force)	kN	22.6	25.5	56.9	83.4	113	142	191	
慣性モーメント Moment of inertia J	kg·m <sup>2</sup>	0.006	0.014	0.048	0.16	0.34	0.75	2.30	
質量 Weight with standard soft blank jaws	kg	3.7	6.3	13.3	22	39	62	116	
対応シリンダ Matching cylinder									
HH31C	形式番号 Series number	4	5	---	---	---	---	---	
	最高使用圧力 Max. pressure to operate chuck	MPa	3.5	3.5	---	---	---	---	
C1TA	形式番号 Series number	---	---	115	140	165	190	(215)	
	最高使用圧力 Max. pressure to operate chuck	MPa	---	---	2.8	2.6	2.8	3.3	
HH4C	形式番号 Series number	80	80	100	125	140	160	180	
	最高使用圧力 Max. pressure to operate chuck	MPa	2.8	3.2	2.8	2.6	2.8	2.9	
H05CH	形式番号 Series number	200	200	200	250	300	300	---	
	最高使用圧力 Max. pressure to operate chuck	MPa	0.4	0.5	0.7	0.6	0.6	0.7	

- 注：1. この値の4倍がGDに相当します。  
2. 回転シリンダの最高回転数が低い場合には、その回転数に合わせてください。  
3. 把握爪の寸法は標準生爪寸法表を参照願います。
- Note: 1. The four times of this value is equivalent to GD.  
2. When the Max. speed of a rotating cylinder is lower than that of a chuck, observe that of a rotating cylinder.  
3. The dimensions of top jaws are on the pages of "Standard soft blank jaw".
- 注：( )の形式は受注生産です。 Note: Parenthesized models are made to order.

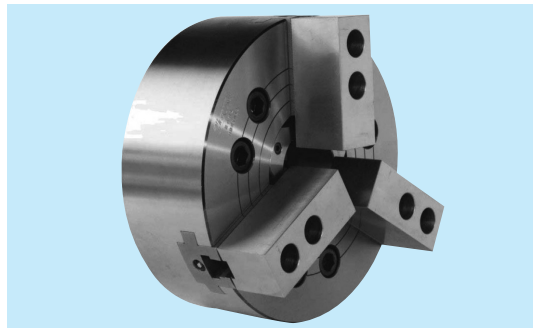

記号 Symbol	形式番号 Series number H037M							
	4	5	6	8	10	12	(15)	
A	110	135	168	210	254	304	381	
B2	Min. 36	41	61	68	92	110	140	
C	H7 100	115	140	190	230	280	350	
D	4	4	5	5	5	5	7	
E	54	54	82	92	105	115	137	
F	82.6	82.6	104.8	133.4	171.4	200	250	
G	3-M10	3-M10	6-M10	6-M12	6-M16	6-M20	6-M20	
H	10.5	10.5	14	16	22	26	26	
J	Max. M18 ×1.5	M24 ×1.5	M55 ×2	M60 ×2	M85 ×2	M100 ×2	M130 ×2	
J1	25	25	35	40	45	50	60	
K	12	12	30	32	37	42	48	
K1	M28 ×1.5	M33 ×1.5	---	---	---	---	---	
L1	Max.	10	10	15	18	22	25	28
	Min.	0	0	0	0	0	0	0
L2	14	14	20	23	27	30	35	
M	21	26	45	52	75	91	118	
N	Max.	20	22.5	36.25	38.8	53.3	63.8	81.5
	Min.	17.3	19.8	33.1	35	48.65	58.5	75.55
O	Max.	13.5	22.5	18	31.5	33	40.5	51
	Min.	6	6	6	9	12	10.5	12
Q	13	13	17	21	21	28	30	
R	---	---	15°	15°	15°	15°	15°	
W1	28	33	59	66	90	108	139	
W2	35	40	---	---	---	---	---	
X	27	27	39	44	49	64	69	
Z1	95	120	---	---	---	---	---	
Z2	深さ Depth	M6 -10	M6 -10	---	---	---	---	

